

Engine Isuzu A-6BG1QC-02 / 6.49 L
Fuel Type Diesel
Capacity @ 600 mm LC 7,000 kg

CLG2070H

DIESEL
PNEUMATIC TIRE FORKLIFTS



TOUGH WORLD. TOUGH EQUIPMENT.

CLG2070H SPECIFICATIONS >>>

General	Model	1			CLG2070H	
	Power Type	2			Diesel	
	Base Capacity	3	@ rated load center	kg	7,000	
	Load Center	4		mm	600	
Weights	Service Weight	5	unloaded	kg	9,300	
	Axle Load	6	loaded / unloaded, front	kg	14,460 / 3,800	
		7	loaded / unloaded, rear	kg	1,840 / 5,500	
Tires	Tire Type	8			Pneumatic	
	Wheels	9	front / rear		4 / 2	
	Wheelbase	10		mm	2,250	
	Tire Size	11	front			8.25-15-14PR
		12	rear			8.25-15-14PR
13	Tread Width	front / rear			1,474 / 1,730	
Mast	Max. Fork Height	14	with std 2-stage mast	mm	3,000	
	Freelift	15	with std 2-stage mast	mm	210	
	Height, Upright Lowered	16	with std 2-stage mast	mm	2,534	
	Height, Upright Extended	17	with std 2-stage mast	mm	4,377	
	Mast Tilt, Fwd/Back	18	with std 2-stage mast	deg	6° / 12°	
	Carriage	19	width	mm	1,840	
	Fork Spread	20	minimum / maximum	mm	300 / 1,840	
	Fork Dimensions	21	T x W x L	mm	65 x 150 x 1,520	
Chassis	Length to Fork Face	22	with std 2-stage mast	mm	3,650	
	Overall Width	23		mm	2,040	
	Overhead Guard Height	24		mm	2,520	
	Turning Radius	25	minimum outside	mm	3,560	
	Fork Overhang	26	with std 2-stage mast	mm	592	
	Right Angle Stack	27	add load length and clearance	mm	5,170	
	Ground Clearance	28	minimum loaded	mm	203	
		29	center of wheelbase	mm	250	
Performance	Travel Speed	30	loaded / unloaded	km/h	23 / 25	
	Lift Speed	31	loaded / unloaded	m/s	0.44 / 0.53	
	Lower Speed	32	loaded / unloaded	m/s	0.55 / 0.40	
	Max. Drawbar Pull	33	loaded	kg	5,500	
	Max. Gradeability	34	loaded / unloaded	%	20 / 20	
Systems	Brakes	35	service		Foot / Hyd	
		36	parking		Hand / Mech	
		37	manufacturer		Isuzu	
	Engine	38	model			A-6BG1QC-02
		39	emission compliance			Euro Stage I
		40	cylinders			6
		41	displacement	liter		6.49
		42	rated power	kW/rpm		82.4 / 2,000
		43	max. torque	N-m/rpm		416.8 / 1,500

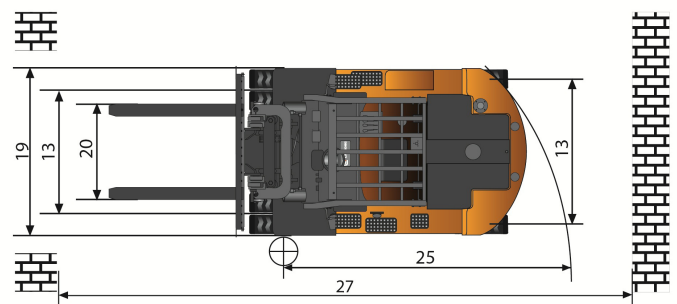
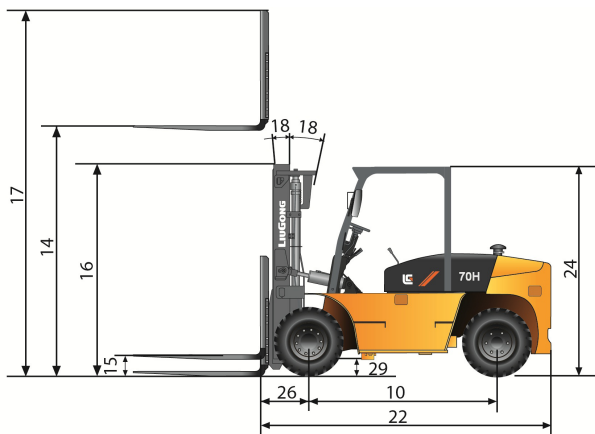

Guangxi Liugong Machinery Co., Ltd.

No. 1 Liutai Road, Liuzhou, Guangxi 545007, PR China
 T: +86 772 3886124 E: overseas@liugong.com
 www.liugong.com

06/2017 Designed by LiuGong

Specifications and designs are subject to change without notice. Machines shown may include optional equipment.

