

CPD30/35-EJL Configuration

Component	Configuration	CPD30EJL	CPD35EJL	Component	Configuration	CPD30EJL	CPD35EJL
Terminal standard	European standard terminal	●	●	Mast	2-Stage 4m mast	○	○
controller	Jiachen Electric-Control	●	●		2-Stage 4.5m mast	○	○
Front Tire	Pneumatic tire	●	●		3-Stage 4m mast	○	○
	solid tires	○	○		3-Stage 4.5 m Full-Free Lift Mast	○	○
Rear Tire	White environmental solid tire	○	○	Fork carriage	Fork carriage	●	●
	Pneumatic tire	●	●	carriage	carriage	●	●
	solid tires	○	○	Fork Pallet Fork	1070mm	●	●
Seat	8mm thick rim pneumatic tire	○	○		1220mm	○	○
	Vibration-absorbing seat, seat belt (retractable)	●	●		1370mm	○	○
Overhead guard	Benfeng semi-suspension seat	○	○		1520mm	○	○
	Overhead guard	●	●		1670mm	○	○
Distribution valve	Benfeng suspension seat	○	○		1820mm	○	○
	2 spool valve	●	●		1970mm	○	○
	Three-Spool Valve	○	○	2120mm	○	○	
Motor	4 spool valve	○	○	2440mm	○	○	
	Wanxin Motor	●	●	Without fork	○	○	
battery	Hepu motor	○	○	Attachment	Cascade side shifter	○	○
	Lithium battery: 205Ah	●	●	China side shifter	○	○	
	Lithium battery: 280Ah	○	○	Decal	Chinese decal	●	●
Battery Charger	Lithium battery: 350Ah	○	○	English decal CE	○	○	
	Lithium battery charger three-phase 380V 80V/65A	●	●	Lithium battery heating	○	○	
	Lithium battery charger single phase 220V 80V/35A	○	○	Electric Fan	○	○	
	Lithium battery charger three-phase 380V 80V/100A	○	○	Additional set of lines (quadruple valve)	○	○	
	Lithium battery charger, three-phase 380V 80V/150A	○	○	Additional two sets of lines	○	○	
Mast	Lithium battery charger three-phase 380V 80V/200A	○	○	Other accessories	Additional set of lines	○	○
	2-Stage 3m mast	●	●	OPS control	○	○	
	2-Stage 3.3m mast	○	○	Fleet Management System	○	○	
	2-Stage 3.5m mast	○	○	Seat belt OPS	○	○	
				Additional set of oil lines (quadruple valve)	○	○	

Note: ● Standard configuration ○ Optional configuration



TOUGH WORLD. TOUGH EQUIPMENT.

Liuzhou Liugong Forklift Co., Ltd.
 No. 1 Yanghe Avenue, Yanghe Industrial
 New Zone, Liuzhou City, Guangxi
 Zip Code (P): 545006
 Sales Hotline (T): 0772-2040713
 Service Hotline (T): 0772-2040720/ 0772-2040721
 E-mail (E): liugonglrs@liugong.com
 Website (W): www.lgforklift.cn

LG-PB-CPD30/35-EJL -2211中文

The Liugong series of logos herein, including but not limited to word marks, device marks, letter of alphabet marks and combination marks, as the registered trademarks of Guangxi Liugong Group Co., Ltd. are used by Guangxi Liugong Machinery Co., Ltd. with legal permission, and shall not be used without permission. Specifications and designs are subject to change without notice. Illustrations and pictures may include optional equipment and may not include all standard equipment. Equipment and options varies by regional availability.



Official website



Media Platform

E-SERIES CPD30/35-EJL

Lithium Battery Counter-balanced Forklifts

TOUGH WORLD. TOUGH EQUIPMENT.

CPD30/35-EJL PRODUCT FEATURES

1 Reliability and Stability

2 Green Energy-Saving

3 Easy Maintenance

The E-series lithium battery forklift is a new generation of forklift developed by Liugong for light and medium working conditions based on the 3T/3.5T E series National IV internal combustion engine platform according to market demand. The fuel forklift is upgraded to a green, energy-saving, economical, reliable and stable lithium battery forklift, which can easily replace the general internal combustion working condition.



Whole Vehicle LED Lighting System

- LED lights of whole vehicle with energy-saving, high brightness and long life



Robust and Stable Overhead Guard

- High strength overhead guard
- Thicken the columns of the overhead guard to make it stronger



Sturdy Rear Columns

- 130mm ultra-wide rear column with solid and sturdy



Extra Wide Field of Visibility Mast

- The wide-view mast is upgraded with 440 high-strength steel, which increases its strength by 35% and has a wider field of visibility, greatly improving operational safety



Ergonomic Cab

- Ergonomically optimize the cab, reasonably layout the operating levers, and arrange the height of accelerator and brake pedal on the same plane, so as to effectively alleviate the driver's fatigue;
- Equipped with a small steering wheel to increase the operating space



High Fulcrum Tilt Cylinder Mounting

- The high fulcrum design of the tilt cylinder mounting makes the mast more stable and reliable



• The motor is maintenance-free; electric control units, fuses and other related parts can be directly accessed without tools for maintenance

• Ultra short front overhang makes it more stable

• Optimize the heat dissipation of the electrical system to make it more adaptable to harsh working conditions

• The tail frame is integrally stamped and formed, and the front fender of the frame is thickened to 12mm

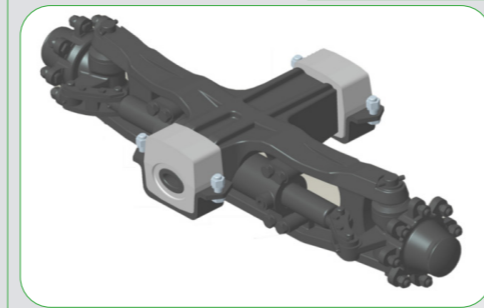

Standard Heavy-duty Casting Steering Axle

The integral casting axle body makes it more robust, and the rear axle is equipped with shock-absorbing and buffering functions and reinforced bearings to make it strong in impact resistance and long in service life

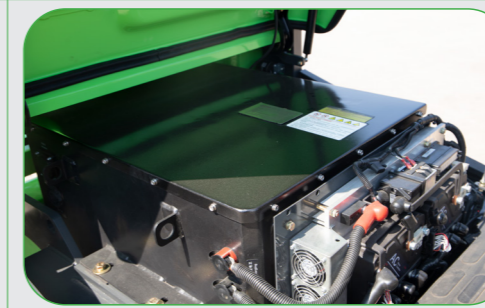

New System Layout

- The new system layout makes the electrical efficiency high and the heat dissipation efficient so as to achieve the purpose of long-term operation
- Standard 205Ah lithium battery, 65A charger, fast charging, more large capacity optional, no worries about battery life



Large Angle Opening of Engine Hood

- The opening angle of the hood is large, and the battery, electric control, and motor can be accessed directly after opening the hood, which makes maintenance more convenient

Removing Floor with Tool-free

- Simple operation, saving time and labor for routine maintenance



Steering Axle

- Enlarging the steering axle angle, thickening the oil cylinder and replacing ordinary bearings with tapered roller bearings, so as to achieve high reliability, small turning radius and less tire wear



Configure an External Charger

- External 65A charger, input voltage three-phase 380V; optional 100A or 150A charger to achieve fast charging

AFTER-SALE WITHOUT WORRY

All products are strictly controlled in accordance with ISO9001 and ISO14000 standards from design and development to after-sales service. Each product has passed the in-factory load test, and the test results prove that the product quality is high-quality and reliable and meets the actual requirements of users.



Provide Solutions



Service Staff In Pace



Completed from Response to Service

OPERATING CONDITIONS



CPD30-EJL CAPACITY

Mast type	Max. Lift Height (mm)	Mast height (mm)	Mast tilt (°)	Free lift height (mm)	Load capacity (Load center 500mm)(kg)		Weight (with standard fork)(kg)
					With standard fork	With side shifter	
2-Stage ordinary mast	CPD30-EJL				CPD30-EJL	CPD30-EJL	CPD30-EJL
	3000	2120	6/12	145	3000	2750	4160
	3300	2270	6/12	145	3000	2750	4186
	3500	2370	6/12	145	2750	2600	4209
	4000	2670	6/6	145	2600	2500	4286
	4500	2920	6/6	145	2400	2300	4300
	5000	3220	3/6	145	2200	2100	4374
	5500	3670	3/6	145	2100	2000	4421
Full-Free Lift - 2-Stage Mast	6000	4020	3/6	145	2000	1900	4496
	2500	1870	6/12	714	2500	2250	4176
	3000	2120	6/12	964	3000	2750	4220
	3500	2370	6/12	1214	2750	2600	4269
Full-Free Lift 3-Stage Mast	3600	1815	6/6	659	2650	2450	4355
	4000	1950	6/6	794	2450	2250	4390
	4500	2120	6/6	964	2250	2050	4430
	4700	2190	6/6	1034	2100	1950	4450
	5000	2295	3/6	1134	1900	1600	4500
	5500	2450	3/6	1304	1700	1450	4590
	6000	2630	3/6	1474	1500	1300	4640

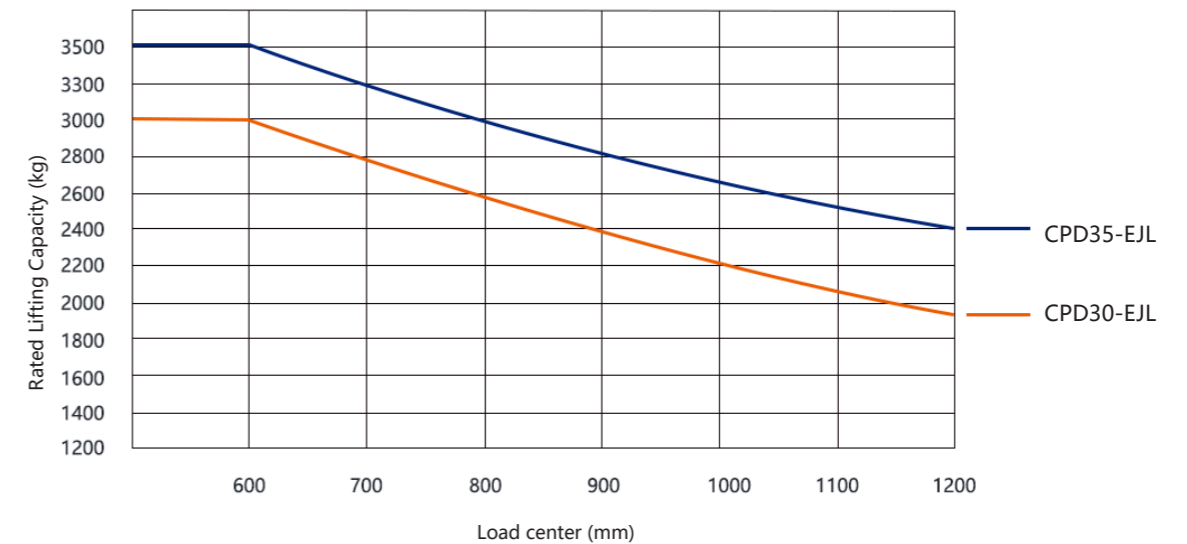

CPD35-EJL CAPACITY

Mast type	Max. Lift Height (mm)	Mast height (mm)	Mast tilt (.)	Free lift height (mm)	Load capacity (Load center 500mm)(kg)		Weight (with standard fork)(kg)
					With standard fork	With side shifter	
CPD35-EJL					CPD35-EJL	CPD35-EJL	CPD35-EJL
2-Stage ordinary mast	3000	2120	6/12	145	3500	3250	4490
	3300	2270	6/12	145	3450	3200	4516
	3500	2370	6/12	145	3250	3100	4539
	4000	2670	6/6	145	3100	3000	4629
	4500	2920	6/6	145	2900	2800	4673
	5000	3220	3/6	145	2700	2600	4717
	5500	3670	3/6	145	2600	2500	4770
	6000	4020	3/6	145	2500	2400	4815
Full-Free Lift - 2-Stage Mast	2500	1870	6/12	714	3000	2750	4490
	3000	2120	6/12	964	3500	3250	4530
	3500	2370	6/12	1214	3250	3100	4579
Full-Free Lift 3-Stage Mast	3600	1815	6/6	659	3150	2950	4715
	4000	1950	6/6	794	2950	2750	4750
	4500	2120	6/6	964	2750	2550	4790
	4700	2190	6/6	1034	2600	2350	4810
	5000	2295	3/6	1134	2400	2100	4960
	5500	2450	3/6	1304	2200	1950	5140
	6000	2630	3/6	1474	2000	1800	5190

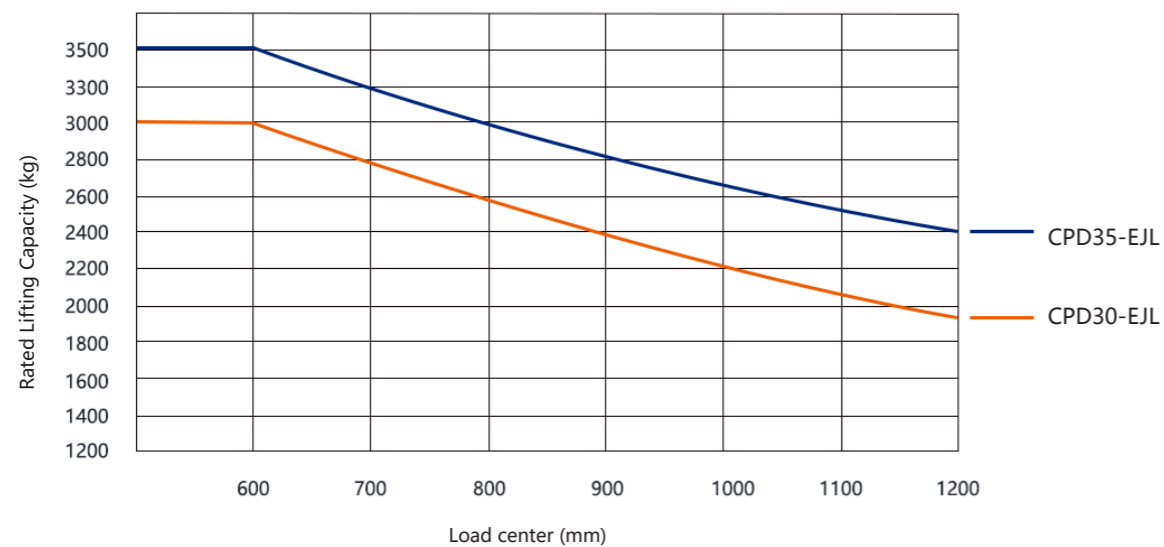

CPD30/35-EJL SPECIFICATION

Overall	Model	1	CPD30-EJL		CPD35-EJL			
	Type of engine	2	Electric	Electric	Electric	Electric		
Overall	Rated Lifting Capacity	3	Rated load center	kg	3000	3000	3500	3500
	Load center	4		mm	500	500	500	500
	Dead Weight	5	Unloaded	kg	4160	4245	4490	4575
Weight	Axle load	6	Full load/unloaded, front axle	kg	6498/1836	6522/1860	7246/1787	7270/1812
	Axle load	7	Full load/unloaded, rear axle	kg	742/2404	802/2464	818/2777	878/2837
Tire	Type of tire	8		Pneumatic tire	Pneumatic tire	Pneumatic tire	Pneumatic tire	
	Tires number	9	Front wheel/rear wheel		2/2	2/2	2/2	2/2
	Wheelbase	10		mm	1760	1760	1760	1760
	Tire Size	11	Front Tire		28×9-15-14PR	28×9-15-14PR	28×9-15-14PR	28×9-15-14PR
	Tire Size	12	Rear wheel		6.5-10-10PR	6.5-10-10PR	6.5-10-10PR	6.5-10-10PR
	Track (thread)	13	Front wheel/rear wheel	mm	1005/980	1005/980	1005/980	1005/980
Mast	Lift height	14	std 2-Stage mast	mm	3000	3000	3000	3000
	Free lift	15	std 2-Stage mast	mm	145	145	145	145
	Height, mast lowered	16	std 2-Stage mast	mm	2120	2120	2120	2120
	Height, mast extended	17	std 2-Stage mast	mm	3605	3605	3605	3605
	Mast tilt, fwd/back	18	std 2-Stage mast	deg	6/12	6/12	6/12	6/12
	Fork carriage	19	Width	mm	1100	1100	1100	1100
	Fork spread	20	Min/Max	mm	272/1072	272/1072	272/1072	272/1072
	Fork dimensions	21	T x W x L	mm	45×122×1070	45×122×1070	50×122×1070	50×122×1070
Chassis	Overall Length (to the front end of the fork)	22	std 2-Stage mast	mm	2720	2720	2778	2778
	Overall width	23		mm	1225	1225	1225	1225
	Overhead guard height	24		mm	2150	2150	2150	2150
	Minimum Turning Radius	25		mm	2450	2450	2508	2508
Performance	Travel speed	26	Full load/unloaded	km/h	12/13	12/13	12/13	12/13
	Lift speed	27	Full load/unloaded	mm/s	290/400	290/400	290/400	290/400
	Lower speed	28	Full load/unloaded	mm/s	440/430	440/430	440/430	440/430
	Ground clearance	29	central chassis	mm	150	150	150	13180
	Maximum Gradeability	30	5-minute working system	%	15	15	15	15
	System	electric-control	31	Travel /Work Pump		Jiachen	Jiachen	Jiachen
Motor		32	Drive motor power	kW	10	10	10	10
		33	Work pump motor power	kW	15	15	15	15
Battery		34	Types		Lithium battery	Lithium battery	Lithium battery	Lithium battery
		35	Voltage	V	80	80	80	80
		36	Capacity (5h)	Ah	205	280/350	205	280/350

